

Çift Tartım Tek İstasyon Un Paketleme Makinesi

Flour Bagging Machine System With Double Weigh Hopper & Single Station



Çift Tartım Tek İstasyon Un Paketleme Makinesi

Flour Bagging Machine System With Double Weigh Hopper & Single Station

5/10/25 kg.



4 Haneli Tartım Miktarının Gösterimi
4 Display Indication of the Weighing Quantity



Programlanabilir Tolerans Değerleri
Programmable Tolerance Values



Paket Yapılan Toplam Ürün Miktarı Gösterimi
Total Product Quantity Packaged



Dolum Yapılan Toplam Paket Miktarı Gösterimi
Total Package Quantity in which filling is made



Üst Hazne Seviye Kontrolü
Upper Hopper-Reservoir Level Control



Kullanıcı Uyarı Bilgilendirmeleri
User Warning Information



Opsiyonel Paket Ölçüleri
Optional Package Sizes



Hata Bildirimi ve Kontrolü
Error Notification and Control



Hızlı - Orta -Yavaş Devir
Fast - Medium - Slow Cycle

GENEL ÖZELLİKLER / GENERAL FEATURES

Kapasite Bilgileri: Torbalanacak ürüne ve istenen toleransa göre değişmekle birlikte aşağıdaki paketleme hızı ile ilgili değerler sistemin kapasitesi hakkında bir bilgi verecektir.

- 5 kg'lık Paketlemelerde 3 ton/saat
- 10 kg'lık Paketlemelerde 5,5 ton/saat

10 kg'lık paketlemelerde paket başına tolerans $\pm 0,15$ kg arasında değişir. Ayrıca, paket başına düşen ortalama hata payı ile un veya benzer karakterdeki ürünlerde 5,5 ton/saat kapasite ile çalışması taahhüt edilir.

Paketleme Set Değerleri: Paket dolum ağırlıkları operatör tarafından 5-10 kg arasında tercih edilebilmektedir.

Capacity Information: While it varies according to the product to be bagged and the tolerance required, the values relating to the packaging speed below shall provide some information about the capacity of the system.

- 3 ton/hour in 5 kg bagging
- 5,5 ton/hour in 10 kg bagging

The tolerance per package varies between ± 0.15 kg in the 10 kg packaging. In addition to this, it is undertaken to be operated with 5,5 ton/hour capacity in the products such as flour or in similar characteristics with the average error share per package.

Packaging Set Values: The package filling weights could be preferred between 5-10 kg by the operator.

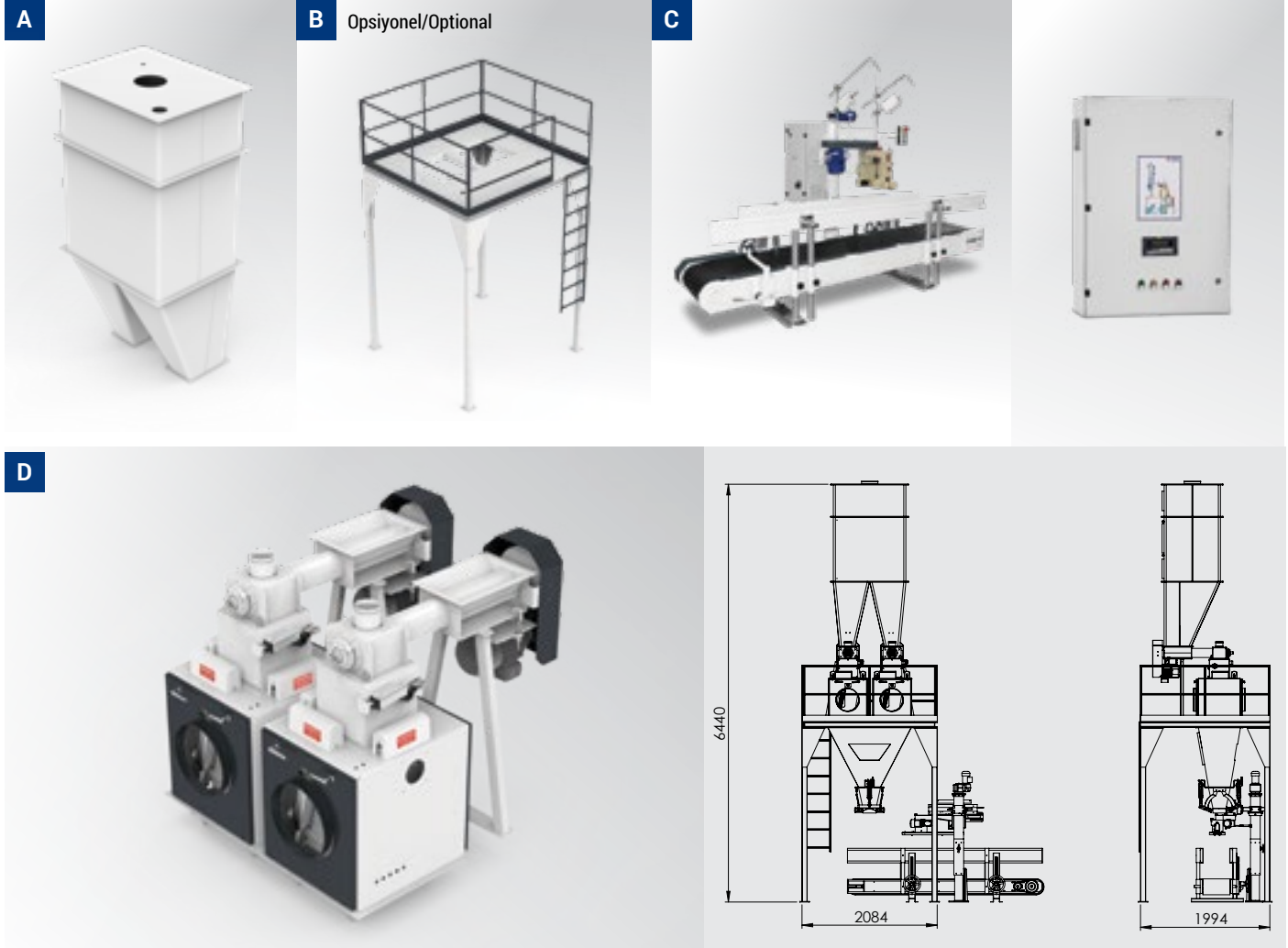

TEKNİK ÖZELLİKLER / TECHNICAL FEATURES

Ürün Kodu/Product Code: **EE-21UT-1025**

Paketlenecek Ürün Cinsi / Type of Product to Be Packed	Un/Flour
Yoğunluk (Un) / Density (Flour)	0,55 Kg/m ³
Maksimum Tartım Ağırlığı / Maximum Weighing Weight	2 x 27 Kg
Tartım Aralığı -Seçenekleri / Weighing Range -Options	5-10-25 Kg
Tartım Hassasiyeti / Weighing Accuracy	\pm % 0,3
Üst Bunker Kapasitesi / Top Bunker Capacity	2053 Litre/Liter
Kefe Kapasitesi / Platter Capacity	50 Litre/Liter
Çıkış Kapasitesi 5 Kg / Output Capacity 5 Kg	3 Ton/Saat - Ton/Hour
Çıkış Kapasitesi 10 Kg / Output Capacity 10 Kg	5,5 Ton/Saat - Ton/Hour

Tartım Adedi 5 Kg / Weighing Units 5 Kg	600 Paket/Saat - Pack./Hour
Tartım Adedi 10 Kg / Weighing Units 10 Kg	550 Paket/Saat - Pack./Hour
Tartım Adedi 25 Kg / Weighing Units 10 Kg	400 Paket/Saat - Pack./Hour
Hava Basıncı / System Pressure	6 - 8 Bar
Hava İhtiyacı / Air Supply (m ³ /Dakika-Min)	20 m ³ /Dakika
Elektrik Beslemesi / Power Supply (VAC) (+5% - 10%)	400 VAC - 50-60 Hz
Elektrik Tüketimi / Electricity consumption	5,9 kW/Saat
Ağırlık / Weight	2150 Kg

INDUSTRY FOR THE FUTURE

www.medyakim.com



ENDÜSTRİYEL

Endüstriyel Elektrik Elektronik San. ve Tic. A.Ş.

K.O.S.B. Evrenköy Cd. 3. Sk.
No:5 Selçuklu/KONYA/TURKEY

T : +90 332 239 09 00
F : +90 332 239 09 02

endustriyel@endustriyel.com
www.endustriyel.com

